

**Catalogue**

---

## Catalogue

General.....	1
The main users are:.....	1
Some advantage of Klifting Rail systems.....	1
Products.....	2
Steel-Copperhead Rails.....	2
Aluminum-Copperhead rails.....	3
Hollow-Aluminium-Copperhead Rails.....	4
Solid-Copper Rails.....	4
Accessory Parts.....	5
Other details.....	6
Adequate Ampere .....	6
Example:.....	6
Formula for Voltage Drop Calculation:.....	6
Other Criterion:.....	7
Effective Length:.....	7
Calculation.....	8
Please offer these information if you need our products.....	8
Contacts.....	10

## General

The well-known Kaiqiang Copperhead Conductor Rails represent a neat and compact arrangement and have proven an outstanding success for safe power feeding of:

Travelling cranes, Loading bridges, Container handling equipment, Monorails, Hoists, Coking machinery and many other applications.

The Copperhead Conductor Rails are available in sizes to meet individual current requirements from 200 to 1,500 Amps.

## The main users are:

Steel mills, Coking plants, Gas works, Cement industries, Ship yards and Dockside enterprises.

Fibreglass-Copperhead Rails are preferably used for applications in corrosive atmospheres and in locations with high humidity.

Aluminium-Copperhead Rails are very economical due to the light weight of the Aluminium and its high conductivity.

Solid-Copper Rails are recommended for heavy duty current rating and for humid locations. The rails are supplied in 6m and 7 m standard lengths, drilled at either end for joint plates or expansion connectors. Shorter lengths are available to coincide with your run way lengths requirements.

We produce a complete range of Accessories, Insulators and Current Collectors. Low weight of rails and saving of steel superstructure and space.

Variation in temperature and resulting expansion and contraction is compensated by standard expansion joints.

## Some advantage of Klifting Rail systems

With Klifting-Systems you eliminate all drawbacks inherent in the conventional design of trolley wires, steel angles and steel rails.

Copperhead Rails ensure an efficient and continuous contact. There is no sparking. The easy maintenance is a proven low factor.

No losses due to interruption of service, no downtime. Negligible wear - almost unlimited life of conductors.

Much lower resistance between copperhead and carbon pick-up shoe.

## Products

### ➤ Steel-Copperhead Rails

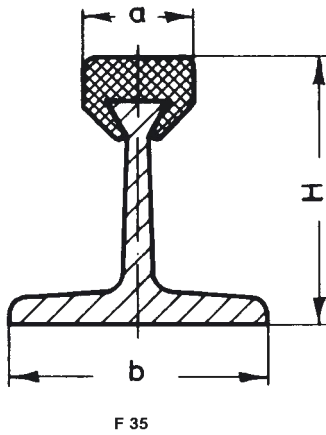

Type	Steel cross section mm <sup>2</sup>	Copper cross section mm <sup>2</sup>	H mm	A mm	b mm	Weight Kg/m	Max continuous mm <sup>2</sup>	Part No.
KS 35/80-6	230	80	15	35	34	15.2	340	200015
KS 35/85-6	230	85	15	35	34.5	15.5	457	200025
KS 35/90-6	230	90	15	35	35	15.8	372	200035
KS 35/100-6	230	100	15	35	36.5	16.34	402	200045
KS 35/130-6	230	130	18	35	36	17.9	492	200055
KS 35/170-6	230	170	18	35	38	20.0	612	200065
KS 35/200-6	230	200	18	35	40	21.6	700	200075

Standard lengths: 6 m (23´ )

Main application: conductor system for heavy monorails, down-shop and cross travel supply for medium duty cranes

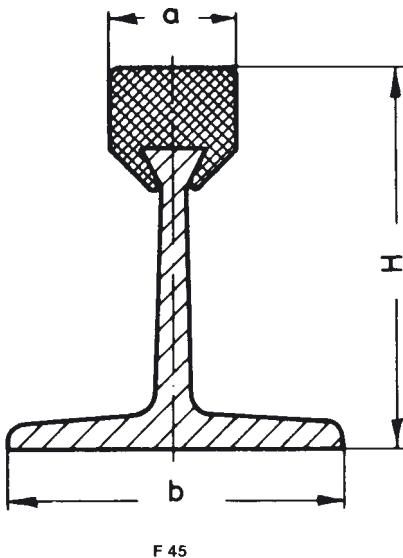

Type	Steel cross section mm <sup>2</sup>	Copper cross section mm <sup>2</sup>	H mm	A mm	b mm	Weight Kg/m	Max continuous mm <sup>2</sup>	Part No.
KS 50/220-6	460	220	20	50	50	35.7	850	200115
KS 50/270-6	460	270	20	50	53	38.4	1000	200225
KS 50/300-6	460	300	20	50	54	40.0	1100	200335
KS 50/350-6	460	350	30	50	61	42.5	1200	200445
KS 50/370-6	460	370	30	50	62	43.5	1300	200555
KS 50/400-6	460	400	30	50	63	45.3	1400	200565

Standard lengths: 6m or 7m, other length according to customer need.

Main application: down-shop and cross travel supply for heavy cranes, loading bridges, coking machinery, rapid transit systems etc.

The steel sections can be supplied galvanized or with anticorrosion paint.

## ➤ Aluminum-Copperhead rails

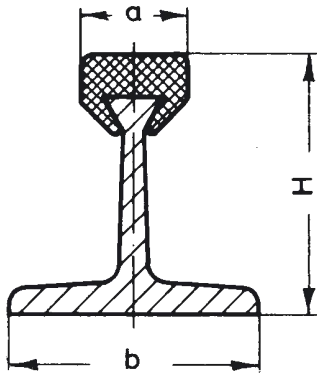

Type	Steel cross section mm <sup>2</sup>	Aluminum cross section mm <sup>2</sup>	Equivalent total copper conductor mm <sup>2</sup>	H mm	A mm	b mm	Weight Kg/m	Max continuous mm <sup>2</sup>	Part No.
KA 35/ 30-7	30	265	230	32.5	14.2	35	1.10	600	201010
KA 35/ 50-7	50	265	180	33.0	14.6	35	1.18	675	201020
KA35/100-7	100	265	230	36.0	15.3	35	1.63	800	201030

Standard lengths: 6m or 7m, other length according to customer need.

Main application: conductor system for heavy monorails, down-shop and cross travel supply for medium duty cranes

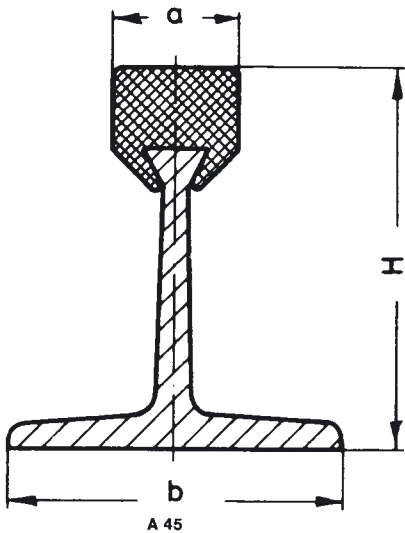

Type	Steel cross section mm <sup>2</sup>	Aluminum cross section mm <sup>2</sup>	Equivalent total copper conductor mm <sup>2</sup>	H mm	A mm	b mm	Weight Kg/m	Max continuous mm <sup>2</sup>	Part No.
KA 45/ 50-7	50	355	225	43.1	14.6	45	1.42	800	201040
KA 45/100-7	100	355	275	46.0	15.3	45	1.87	900	201050
KA 45/150-7	150	355	325	48.3	17.3	45	2.32	1000	201060
KA 45/200-7	200	355	375	50.8	17.3	45	2.77	1100	201070
KA 45/300-7	300	355	475	56.3	17.6	45	3.67	1250	201080
KA 45/400-7	400	355	575	59.3	19.6	45	4.57	1450	201090

Standard lengths: 6m or 7m, other length according to customer need.

Main application: down-shop and cross travel supply for heavy cranes, loading bridges, coking machinery, rapid transit systems etc.

## ➤ Hollow-Aluminium-Copperhead Rails

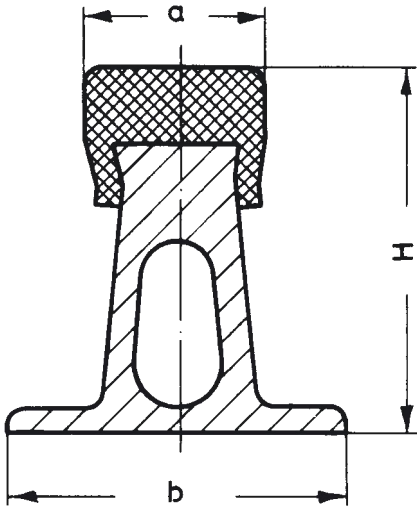

Type	Copper cross section mm <sup>2</sup>	Equival. total copper conductor mm <sup>2</sup>	H mm	A mm	b mm	Weight Kg/m	Max continuous mm <sup>2</sup>	Part No.
KH 45/60-7	60	360	41	22	45	2.15	1000	202060
KH 45/110-7	110	410	42	23	45	2.60	1050	202110
KH 45/150-7	150	450	43	24	45	2.96	1150	202150
KH 45/200-7	200	500	43	25	45	3.41	1200	202200
KH 45/300-7	300	600	49	24	45	4.31	1350	100817

Standard lengths: 6m or 7m, other length according to customer need.

## ➤ Solid-Copper Rails

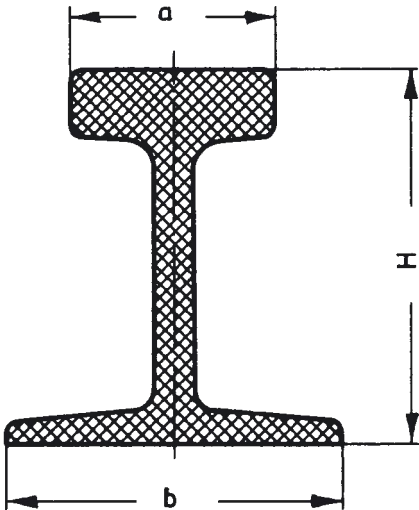

Type	Copper cross section mm <sup>2</sup>	H mm	A mm	b mm	Weight Kg/m	Max continuous mm <sup>2</sup>	Part No.
KC 20/400-7	400	45	12	35	3.55	1050	203400
KC 35/500-7	500	50	16	45	4.45	1200	203500
KC 45/600-7	600	50	25	45	5.32	1350	203600
KC 45/800-7	800	50	27	45	7.12	1550	203800

Standard lengths: 3m or 4.5m, other length according to customer need.

Main application:

C 20/200 and C 35/400 in conjunction with heavy enclosed conductor systems.

C 45/- series for heavy duty current ratings.

**Accessory Parts**

**Current collector**



**Insulator**

**Support**

**Connector**



## Other details

### **Adequate Ampere Capacity must be provided to carry the anticipated electrical loads:**

The total Ampere load is determined from the nominal rated full load current reduced by the duty cycle ( fED) and by a diversity factor for non-simultaneous operation.

The average crane motor duty cycle is usually between 40% and 60%, depending on the type of application.

A diversity factor of 0.4 to 0.7 can be used when there are more than one crane on the same runway.

### **Example:**

3 cranes, each  $I_n = 300$  Amps.

Length of runway: 100 m (330')

Assumed duty cycle: 60% (ED)

Assumed diversity factor: 0.7

Ampere load per crane:  $I_n \times fED = 300 \text{ A} \times 0.78 = 234 \text{ A}$

Ampere load for 3 cranes:  $234 \text{ A} \times 3 = 702 \text{ A}$

Total Ampere load when using

a diversity factor of 0.7:  $702 \text{ A} \times 0.7 = 491.4 \text{ A}$

Selected conductors: ( F 35/100 or: F 45/50 )



### **Formula for Voltage Drop Calculation:**

$$\text{AC: } \Delta u = \sqrt{3} \times I \times L \times Z$$

$$\text{DC: } \Delta u = 2 \times I \times L \times R$$

$\Delta u$  = Voltage drop [V] R = Resistance [Ohm/m]

I = Ampere load [A] L = Length from power feed to end of conductor [m]

Z = Impedance [Ohm/m] L = System length [m]



duty cycle	$f_{ED}$
100%	1.00
80%	0.90
60%	0.78
50%	0.71
40%	0.63
20%	0.45



## Other Criterion:

- Select the conductor cross section to carry the calculated total Ampere load and consider the voltage drop calculation to maintain the limits established by the motor manufacturers. The conductor size and/or number of feed points should be increased in case the drop is exceeding the limitations. For very high Ampere loads it may be necessary to provide booster cables.
- Specify the correct Klifting-conductor by considering the type of application and environment, such as heavy or light.

## Effective Length:

- $l = L$  power feed located at the end of the system
- $l = L/2$  power feed located at the mid-point of the system
- $l = L/4$  power feed located at both ends of the system
- $l = L/6$  power feed located at  $L/6$  from each end of the system

## Calculation

Please offer these information if you need our products.

Company Name: \_\_\_\_\_ Contact \_\_\_\_\_  
Project: \_\_\_\_\_ Address: \_\_\_\_\_  
E-mail: \_\_\_\_\_ Project: \_\_\_\_\_  
Telephone: \_\_\_\_\_ Fax: \_\_\_\_\_  
Date: \_\_\_\_\_

---

1. Type of crane/machine to be electrified: \_\_\_\_\_
  2. Voltage: \_\_\_\_\_ Volts ~/= \_\_\_\_\_ Phases: c/s: \_\_\_\_\_
  3. Length of conductor system: \_\_\_\_\_
  4. Number of conductors required: \_\_\_\_\_ power lines: \_\_\_\_\_ control lines: \_\_\_\_\_ neutral (ground): \_\_\_\_\_
  5. Indoor: \_\_\_\_\_ Outdoor: \_\_\_\_\_
  6. Special site conditions (humidity, dust, chemical influence etc.): \_\_\_\_\_
  7. Temperature conditions: \_\_\_\_\_ °C min., \_\_\_\_\_ °C max.
  8. Type of conductors preferably wanted: \_\_\_\_\_
  9. Number and position of feeder points: \_\_\_\_\_
  10. Mounting position envisaged: \_\_\_\_\_  
(prints and sketches should be submitted whenever obtainable)
  11. Number of cranes / machines fed from the one system: \_\_\_\_\_
  12. Ampere load of each crane / machine: \_\_\_\_\_
  13. Other pertinent data: \_\_\_\_\_
- 
- 

For curved tracks, breaks in system etc. please submit prints and sketches.

---

Motor (please mark run simultaneously and at the same time start the motor)	Crane 1						
	P/(KW)	Rated current			Starting current		
		A	COSφ <sup>N</sup>	%ED	A	COSφ <sup>A</sup>	Start Method
Main Hoisting							
Aux. Hoisting							
Main Traverse							
Aux. Traverse							
Main Travel							
Aux. Travel							
Slewing							
Luffing and any other Service							
The type of motor : K:Squirrel-cage motors; S:Slip-ring motors; F:Inverter motor							
Motor (please mark run simultaneously and at the same time start the motor)	Crane 2						
	P/(KW)	Rated current			Starting current		
		A	COSφ <sup>N</sup>	%ED	A	COSφ <sup>A</sup>	Start Method
Main Hoisting							
Aux. Hoisting							
Main Traverse							
Aux. Traverse							
Main Travel							
Aux. Travel							
Slewing							
Luffing and any other Service							
The type of motor : K:Squirrel-cage motors; S:Slip-ring motors; F:Inverter motor							

## Contacts

### **Shandong Kaiqiang Electric Technology Co.,Ltd.**

ADD: No. 6000 NORTH RING ROAD, LINQU, WEIFANG, SHANDONG, CHINA

### **Baoding Zhongze I/E Co.,Ltd.** (Exclusive sales)

ADD: ROOM 206, INNOVATION CENTER BUILDING, NO.3188, NORTH HENGXIANG STREET, BAODING , HEBEI , CHINA

Tel: 0086-186-0332-3110

Fax: 0086-312-315-2365

Website: [en.klifting.com](http://en.klifting.com)

For further information of C-track festoon system, please contact us in the above ways.

We commit ourselves to constant improvement of our design and processing of the products.

We keep the right of perfecting the instruction book and the product design to achieve the goal.